

RC2110 Wi-Con Series Wireless Humidity Controller



General Description

The RC2110 wireless humidity system controller utilizes reliable Spread Spectrum Radio technology. Together with other existing Trs Systems WH1630 wireless space humidity sensors and DH1630 wireless duct humidity sensors, the RC2110 controller will control the humidification/de-humidification equipment based on the average space humidity (up to 12 zones).

RC2110A Humidification Controller - If the average space humidity is lower than the average space humidity set point, the humidifier will be activated after a preset time delay (adjustable) by a relay output from the RC2110A controller. An optional duct humidity sensor can be assigned as a humidity high limit when needed.

RC2110B De-humidification Controller - If the average space humidity is higher than the average space humidity set point, the de-humidification equipment will be activated after a preset time delay (adjustable) by a relay output from the RC2110B controller.

The maximum radio transmission distance is dependent on building type. The maximum open-air transmission distance is one mile. In a typical commercial building with steel I-beam construction, concrete floors with reinforcing rod, and metal stud walls, it can be expected that transmissions will penetrate vertically through floors and horizontally through 200 to 500 feet of walls, furniture and air. Generally a wireless system will cover at least three floors - one floor above and one floor below the receiver location. In some buildings with favorable transmission characteristics the system may cover more floors.

Features

- Averages inputs from up to 12 wireless wall humidity sensor modules
- Optional wireless duct humidity sensor for high limit application
- Two humidity set points (occ/unocc)
- Sensor Enable – Mini-switch selects remote space sensors to be included in the average humidity computation
- Adjustable time delay for control output to prevent short cycling of equipment.
- Manual (local)/Auto system switch
- Built-in Real Time Clock
- Optional external time clock input
- High intensity LED display for mechanical room or low ambient lighting environment
- Low battery and lost sensor alarm indication and alarm relay output
- Reliable Spread Spectrum technology

Ordering Information

<u>Model</u>	<u>Description</u>
RC2110A	Humidification Controller
RC2110B	De-humidification Controller
WH1630A	Wireless Wall Humidity (3%) Sensor
WH1630C	Wireless Wall Humidity (2%) Sensor
DH1630A	Wireless Duct Mounted Humidity (3%) Sensor
DH1630D	Wireless Duct Mounted Humidity (2%) Sensor
RR1552A	Signal Repeater



Specifications

Input Voltage:

- 24 VAC 60 Hz (+10%/-15%)

Power Consumption

- 4 VA Maximum

Dimensions:

- 9-3/8" x 4-5/8" x 2-3/8"

Operating Conditions:

- 15 F to 125 F
- 5 to 95% non-condensing

Sensor Indicating Ranges:

- Space Humidity, 0-100 %RH
- Duct Humidity, 0-100 %RH
- Accuracy, +/- 3% & +/- 2%

Control Output:

- Three terminals for control output
- (Common, Manual & Auto) – SPST N.O.
- Pilot Duty (1 amp max. at 24VAC)

Low Battery/Lost Transmitter Alarm Output:

- Pilot Duty Relay Contact (SPST N.O., 1 amp max. at 24 VAC)

Set Point Adjustment Range

- 5 % to 95 %

Case

- NEMA4 Enclosure (Light Gray)
- Transparent Cover
- UL94V-2 Flammability Rating

RF Characteristics

- Operating Frequency Channel
 - 932.58 MHz
- Receiver Sensitivity (avg. power)
 - -107 dBm
- Jam Resistance
 - 60 dB out-of-band rejection

Approvals

- FCC part 15.247

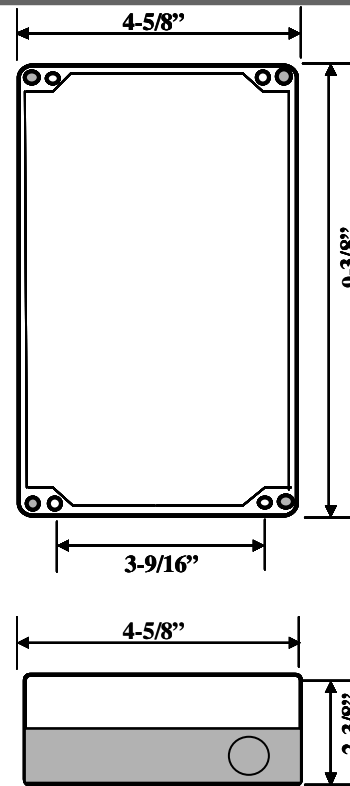

Figure 1

Field Adjustable parameters:

- Space humidity set point
- Space set point differential
- Duct humidity high limit set point
- Duct high limit set point differential
- Day/night setpoints & schedule
- Time of day
- Output time delay
- Sensor high/low limit range (excludes a particular sensor from the average humidity calculation if its humidity is beyond the set point limit range)

LED display:

- Average space humidity
- Space sensors included in the average calculation
- Space humidity set point & differential
- Night mode set point offset
- Time of day & day/night schedule
- Duct humidity (optional)
- Duct high limit set point & differential
- Individual space humidity
- Low Battery & Lost Sensor Alarms
- Sensor limit range for calculation