

OST2630
Wireless Compact Outside Air
Temperature Sensors



General Description

The mesh network OST2630 is a battery operated compact wireless outside air temperature sensor. The sensor is housed in a NEMA4 enclosure and can be mounted anywhere in the shaded area outside of a building.

If needed the distance from the sensor to the receivers can be extended using the Trs RR2552 repeater.

Trs Systems mesh network Series 2000 wireless sensors utilize reliable Spread Spectrum Radio technology. They can be installed easily in minutes eliminating hundreds of feet of wire and saving installation cost while reducing installation labor risks.

The Series 2000 sensor Data-Link LED confirms the data transmission was received by the receiver for fast and reliable positioning of the sensor during installation. *There is no need for special wireless installation equipment or tool.*

Together with the Trs Systems Series 2000 receivers and controllers, the Trs Systems wireless sensors can be used with any LON, BacNet, MODbus, or DDC control system or panel.

The maximum radio transmission distance is dependent on building type. The maximum open air transmission distance is one mile. In a typical commercial building with steel I-beam construction, concrete floors with reinforcing rod, and metal stud walls, it can be expected that transmissions will penetrate vertically through floors and horizontally through 200 to 500 feet of walls, furniture and air. If needed, the distance from the sensor to the receivers can be extended using the Trs RR2552 repeater.

Ordering Information

<u>Model</u>	<u>Description</u>
OST2630A	Compact Outside Air Temperature Sensor in NEMA4 Enclosure

Features

- NO calibration required
- NO wiring needed
- Easy to install
- Battery powered sensors
- Compact UV resistant NEMA4 enclosure
- Wireless Mesh Network – easy to install & relocate sensors without additional wireless installation tools
- Long battery life (approximately 5 years) with standard models
- Low battery alarms
- Reliable Spread Spectrum Mesh Network radio technology

Specifications

- Input Voltage:
 - Battery - One or two type 3.0V LiMNO2 1400 mAH (e.g. Duracell DL123A, Varta CR123A)
- Dimensions:
 - Probe length: 2-14/16"
 - Housing : NEMA4
1-3/4" X 3-1/8" X 5-3/4"
- Operating Conditions:
 - -40 F to 160 F (Sensor Housing)
 - 5 to 95% RH non-condensing
- Open Field Range:
 - One mile line of sight
- Temperature Sensor
 - Sensing Ranges: -40 F to 160 F
 - Accuracy +/- 1 F
 - 12 Bit Resolution
- Transmitter Characteristics
 - Center Transmit Frequency
 - 923.58 MHz
 - Transmitter Power - 11 dB
- Approvals - RF
 - FCC certified

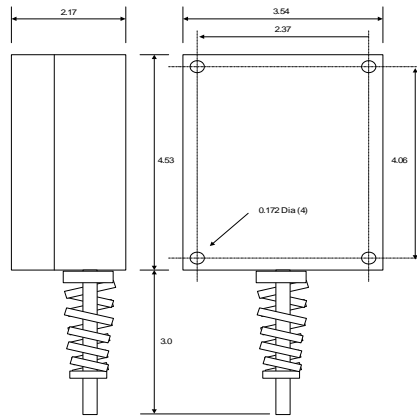

Figure 1 – Enclosure

Installation

Wireless outside air sensors should be installed within 200 to 500 feet of the receiver. RR2552 signal repeaters can be installed as needed to increase transmission distance between sensors and receivers.

Mount the OST2630 sensor on any flat surface outside using four #8 screws (mounting dimensions see Figure 1)

To select the proper sensor location, first install and power the receiver. Observing polarity insert the battery into the sensor to activate it. The mesh networked Series 2000 system does not require any additional wireless equipment to determine the proper location of the sensors.

While the sensor is attempting to connect to the receiver the Data-Link LED will blink rapidly 8-10 times every 10 seconds. Once a connection has been established the Data-Link LED will blink once to indicate the data transmission has been received successfully. The Data-Link LED will continue to blink once for every data transmission. The data transmission rate is programmed into the sensor (normally 1 minute intervals). To manually initiate a data transmission press the push button switch located by the negative terminal of the battery.

The sensor should be installed in the shaded area away from the sun & rain preferably in the north side of the building. For proper performance, the sensor should be oriented with the sensing probe pointing down.

⚠ CAUTION

Sensors, Repeaters and receivers should **NOT** be installed in the following areas:

- Inside metal enclosure/panel
- Inside or immediately next to elevator shaft/elevator banks
- In front of or immediately next to large trees or a large body of water

Transmission distance and performance will be drastically reduced.

Locate and record the duct sensor TXID numbers located on a label on the inside of the enclosure cover.

The sensor has a Low Battery LED that will start to blink continuously when the battery voltage is low. A low battery signal is also sent to the receiver for remote indication that the battery should be replaced. If the battery is not replaced in approximately 2 months the battery voltage will become so low that the Low Battery and Data-Link LEDs will not blink. Replace the battery and the Data-Link LED will start blinking while the sensor is re-establishing communications with the receiver.

Attach the cover of the sensor by installing the four screws to complete the installation.

⚠ CAUTION

Do not use this product in any safety related applications where human life may be affected.

Limitation of Liability - Trs Systems' liability shall not exceed the purchase price paid for the products giving rise to any liability. In no event shall Trs be liable for any special, consequential or incidental damages arising in any way from using this product by the customers.