

## RT2630 Wireless Analog & Digital Sensor Input Concentrators



### General Description

The Series 2000 RT2630 wireless remote Analog/Digital Sensor Input Concentrator accepts digital and analog sensor/control inputs and transmits wirelessly to the receiver.

It utilizes reliable Spread Spectrum Mesh Network Radio technology. It can be installed easily in minutes eliminating hundreds of feet of wire and saving installation cost while reducing installation labor risks.

The Series 2000 sensor Data-Link LED confirms the data transmission was received by the receiver for fast and reliable positioning of the sensor during installation. *There is no need for special wireless installation equipment or tool.*

Together with the Trs Systems Series 2000 receivers and controllers, the Trs Systems wireless digital transmitter can be used with any LON, BACnet, MODbus, or DDC control system or panel.

The maximum radio transmission distance is dependent on building type. In a typical commercial building with steel I-beam construction, concrete floors with reinforcing rod, and metal stud walls, it can be expected that transmissions will penetrate vertically through floors and horizontally through 200 to 500 feet of walls, furniture and air.

### Ordering Information

#### Model Description

RT2630	Input Concentrator with 4 Digital Inputs and Different Analog Inputs
	<b>A</b> 4 Resistance Inputs (20Kohms)
	<b>B</b> 4 Voltage Inputs (0-10VDC)
	<b>E</b> 4 Current Inputs (0-20 mA)
	<b>Power Options</b>
	<b>DC</b> 24VDC or Battery
	<b>AC</b> 24VAC or Battery
	<b>Minimum Transmission Interval</b>
	<b>Blank</b> Every 1 minute
	<b>-F</b> Every 5 Minutes
	<b>-G</b> Every 30 Seconds
	<b>-X</b> Every 10 seconds
RT2630	A AC

**Example:** RT2630A-AC Input Concentrator with 4 resistance inputs (20Kohm), 24VAC and a minimum transmission interval of 1 minute

**Note 1:** Less than 4-5 year battery life due to more frequent transmissions. Use external power for the 5 & 30 second models

### Features

- Battery powered or 24 VAC/DC powered remote wireless sensor input modules
- Up to 4 analog inputs (20KOhm, 0-10VDC & 0-20mA types) and 4 digital inputs (relay contact)
- No calibration required
- Wireless – easy to install & relocate
- Long battery life (4 to 5 years)
- Low battery LED + remote low battery alarm notification
- Optional 24VAC or 24VDC power
- Reliable Spread Spectrum Mesh Network wireless technology

### Specifications

#### Input Voltage:

- Battery Option - Size:2/3A, Type: Lithium 3.0V 1400 mAh (e.g. Duracell DL123A)
- 24 VAC 60 Hz or 24VDC Option

#### Operating Conditions:

- 15 F to 125 F
- 5 to 95% RH non-condensing

#### Open Field Range:

- One mile line of sight

#### Digital Inputs (4)

- Contact Closure

#### Analog Inputs (4):

- Resolution – 12 bits
- Four 20 Kohm or
- Four 0 to 10 VDC or
- Four 0 to 20 mA

#### Case:

- Dimensions - 7.3" x 4.7" x 2.25"
- Flame Retardant ABS Plastic (Black)
- UL Flame Rating – 94-5VA

#### Transmitter Characteristics

- Center Transmit Frequency
  - 923.58 MHz
- Transmitter Power – 11 dB

#### Approvals

- FCC certified

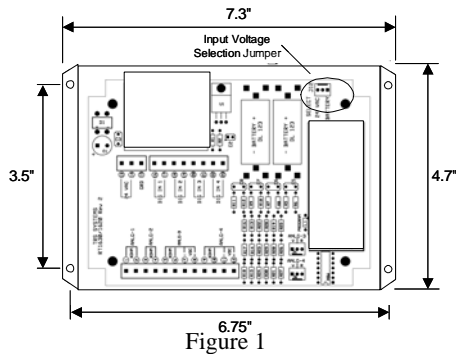

Figure 1

Wireless digital transmitters should be installed within 200 to 500 feet of the receiver. RR2552 signal repeaters can be installed as needed to increase transmission distance between sensors and receivers.

### Sensor Location

To select the proper sensor location first install and power the receiver. Observing polarity insert the battery into the sensor to activate it (For battery operation, move the voltage selection jumper to battery mode before inserting the battery). The mesh networked Series 2000 system does not require any additional wireless equipment to determine the proper location of the sensors.

While the sensor is attempting to connect to the receiver the Data-Link LED will blink rapidly 8-10 times every 10 seconds. Once a connection has been established the Data-Link LED will blink once to indicate the data transmission has been received successfully. The Data-Link LED will continue to blink once for every data transmission. The data transmission rate is programmed into the sensor (normally 1 minute intervals). To manually initiate a data transmission press the push button switch located by the negative terminal of the battery.



#### CAUTION

**Sensors, Repeaters and receivers should NOT be installed in the following areas:**

- Inside metal enclosure/panel
- Inside or immediately next to elevator shaft/elevator banks
- In front of or immediately next to large trees or a large body of water

**Transmission distance and performance will be drastically reduced.**



#### CAUTION

**Do not use this product in any safety related applications where human life may be affected.**

*Limitation of Liability - Trs Systems' liability shall not exceed the purchase price paid for the products giving rise to any liability. In no event shall Trs be liable for any special, consequential or incidental damages arising in any way from using this product by the customers.*

### Installation

Once the location has been determined, mount the RT2630 remote transmitter on a wall using four #8 screws (mounting dimensions see Figure 1). Determine if the RT2630 remote transmitter will be powered by 24 VAC or by batteries on a permanent basis.

#### For 24 V Operation

If the device is to be powered by 24 V (AC or DC), connect 24 V to the input terminals using 18 AWG wire.

#### For Battery Operation

If the device is to be powered using the optional DL123A batteries – remove the voltage selection jumper (see Figure 1) and reposition it for battery operation.

**NOTE: The device is shipped with the voltage selection jumper installed in the 24 V position. For proper operation it is important to use the correct type of battery. Size: 2/3A, Lithium 3.0V 1400 mAh (e.g. Duracell DL123A) batteries.**

Installing the battery or applying 24 VAC will activate the transmitter.



#### CAUTION

**Observe battery polarity when installing battery. Do not use 3.6V LiSOCl<sub>2</sub> batteries With 3.0V LiMNO<sub>2</sub> batteries in the same device.**

#### Sensor Inputs

Wire the sensor inputs to the appropriate terminals using 18 AWG wire.

Record the sensor location on the wiring label located inside the cover.

Attach the cover using the four screws.