

**RC2105 Series 2000
Wireless Steam or Hot Water
Receiver-Controller**



General Description

The RC2105 Series 2000 wireless heating system controller utilizes reliable Spread Spectrum Radio technology. Together with other existing Trs Systems WT2630A wireless space sensors and OST2630 wireless outside air temperature (OSA) sensors, the RC2105 controller will control the boiler system based on the average space temperature (up to 12 zones) and wireless outside air temperature. If the OSA temperature is below OSA set point and the average temperature is lower than the average space temperature set point, the heating system will be activated after a preset time delay (adjustable) by a relay output from the RC2105 controller to the boiler control system. The RC2105 provides maximum flexibility with extensive system adjustability, sensor selectability, alarms and reliable wireless sensor capability.

The RC2105 Series 2000 is also capable of communicating **wirelessly** with the Trs Systems RM9520 Receiver/Server. This enables the user to control and monitor their buildings remotely through the Local Area Network and/or the Internet.

The maximum radio transmission distance is dependent on building type. The maximum open-air transmission distance is one mile. In a typical commercial building with steel I-beam construction, concrete floors with reinforcing rod, and metal stud walls, it can be expected that transmissions will penetrate vertically through floors and horizontally through 200 to 500 feet of walls, furniture and air. Generally a wireless system will cover at least three floors - one floor above and one floor below the receiver location.

Features

- Averages inputs from up to 12 wireless wall sensor modules
- Wireless outside air temperature input
- Two temperature set points (day/night)
- Outside air temperature override
- Sensor Enable – Mini-switch selects remote space sensors to be included in the average temperature computation
- Adjustable time delay for control output to prevent short cycling of equipment.
- Manual (local)/Auto system switch
- Automatic manual mode on power failure
- Summer/Winter mode switch
- Built-in Real Time Clock
- Optional external time clock input
- Wireless remote control and monitoring
- High intensity LED display for mechanical room or low ambient lighting environment
- Low battery and lost sensor alarm indication and alarm relay output
- Space temperature low limit alarm indication and alarm relay output
- Reliable Spread Spectrum technology

Ordering Information

<u>Model</u>	<u>Description</u>
RC2105YA-2K	One controller with four WT2630A wireless space sensors and one OST2630 Wireless OSA sensor
RC2105YB-2K	One controller with eight WT2630A wireless space sensors and one OST2630 Wireless OSA sensor
RC2105YC-2K	One controller with twelve WT2630A wireless space sensors and one OST2630 Wireless OSA sensor

Other System Components

<u>Model</u>	<u>Description</u>
WT2630A	Wireless Wall Temperature Sensor
OST2630	Wireless Compact OSA Temperature Sensor
RR2552B	Signal Repeater



Specifications

Input Voltage:

- 24 VAC 60 Hz (+10%/-15%)

Power Consumption

- 4 VA Maximum

Dimensions:

- 9-3/8" x 4-5/8" x 2-3/8"

Operating Conditions:

- 15 F to 125 F
- 5 to 95% non-condensing

Sensor Indicating Ranges:

- Outside air sensor, -40 deg to 160 deg F
- Space Temperature, 32 deg to 104 deg F
- Accuracy, +/- 1 deg F

Boiler System Control Output:

- Three terminals for heating system enable output
- (Common, Manual & Auto) – SPST N.O.
- Pilot Duty (1 amp max. at 24VAC)

Low Battery/Lost Transmitter Alarm Output:

- Pilot Duty Relay Contact (SPST N.O., 1 amp max. at 24 VAC)

Low Limit Alarm Output:

- Pilot Duty Relay Contact (SPST N.O., 1 amp max. at 24 VAC)

Set Point Adjustment Range

- 35 deg F to 95 deg F

Case

- NEMA4 Enclosure (Light Gray)
- Transparent Cover
- UL94V-2 Flammability Rating

RF Characteristics

- Operating Frequency Channel
 - 923.58 MHz
- Receiver Sensitivity (avg. power)
 - -107 dBm
- Jam Resistance
 - 60 dB out-of-band rejection

Approvals

- FCC part 15.247

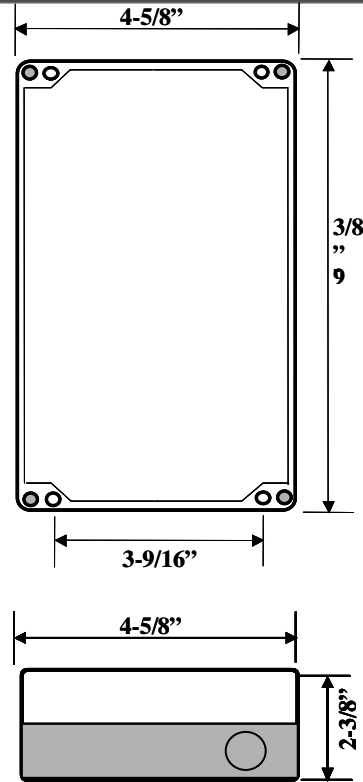

Figure 1

Field Adjustable parameters:

- Space temperature set point
- Space set point differential
- Outside air temperature set point
- OA temperature set point differential
- Day/night setpoints & schedule
- Time of day
- Output time delay
- Sensor high/low limit range (excludes a particular sensor from the average temperature calculation if its temperature is beyond the set point limit range)

LED display:

- Average space temperature
- Space temperatures included in the average calculation
- Space temperature set point & differential
- Night mode set point offset
- Time of day & day/night schedule
- Outside air temperature
- Outside air set point & differential
- Individual space temperature(s)
- Low Battery, Lost Sensor & Space Temperature Low Limit Alarms
- Sensor limit range for calculation